

Metric

→ **Traditional systems for
the reconstruction, repair
and protection of concrete
structures**

kerakoll

Repair of concrete structures.

The strength of a reinforced concrete structure is its ability to stand up to the aggressive stress from the surrounding environment, maintaining its original function for the entire length of its service life.

Dealing with the question of structure durability requires a comparative examination of two main variables: the stress, including aggressive stress from the environment, and the strength of a specific structural element with respect to that stress. However, it is important to note that both these variables are not constant, but vary over time.

This means that, before proceeding to draw up a recovery operation, it is essential to identify the causes at the root of the macroscopic impact deriving from the alteration, the deterioration and/or the damage to reinforced concrete elements, and possibly to the entire structure.

Certain factors - including carbon dioxide, water, aggressive substances such as chlorides and sulphates, thermal variations (freezing and thawing) and possible design and construction errors - play a part in generating forms of deterioration, including efflorescences, infiltrations, corrosion of the reinforcements, cracking and debonding.

Reinforced concrete repair is therefore an operation that requires specific skills. This process starts with analysis of the causes of deterioration and extends to definition of adequate intervention strategies, including selection of suitable types of product to be used.

Causes of deterioration.

The causes of deterioration in reinforced concrete elements can depend on things that directly or indirectly involve both the matrix and the metal reinforcement embedded in it.

More specifically, the main reasons for early deterioration of the structures lie in the use of concretes with a strength adequate for the structural load, as defined by the planner using static calculations, but “undersized” to resist the growing environmental aggression due to the decisive increase in human activities recorded over recent years.

Finally, other causes of damage may lie in the way the concrete is handled on sites: in errors during laying, compacting and curing of the conglomerate that all contribute to make the already poor durability characteristics worse.

Initial micro-cracking may evolve due to the stresses induced by thermal and hygrometric movements, and any aggressive agents present in the environment in which the structure is located can penetrate through these preferential access routes to enhance the deterioration process and bring it forward.

The main causes of deterioration can be divided into 3 macro-categories:

- **chemical causes**
- **physical causes**
- **mechanical causes**



Chemical deterioration

Two very frequent factors among the chemical causes of concrete deterioration are carbonation and chloride attack.

The first of these phenomena occurs due to the dissolution of carbon dioxide in the water, while the second is caused by the dissolution of salts.

Carbonation is the chemical process that is triggered when carbon dioxide, which is naturally present in the air, comes into contact with the concrete, modifying the alkaline properties of the conglomerate. Concrete is characterised by an alkaline environment (with a pH of over 13) which is favourable to the protection of metal reinforcements as in these conditions a protective film is formed on the metal elements, preventing them from rusting. However, when carbon dioxide manages to penetrate through the pores in the concrete, a decrease in the pH occurs due to carbonation, that is to say transformation of the calcium hydroxide into calcium carbonate. In this context, corrosion caused by chlorides or carbon dioxide causes a reduction in the section of reinforcement bars, adhesion between steel and concrete and a loss of cover layer portions, which results in an overall decrease in rigidity of the structural element, with inevitable repercussions on the deformation and functionality of the entire structure.



Physical deterioration

The durability of reinforced concrete structures may be compromised by thermal gradients due to the natural variations in temperature between day and night and through the seasons. If they are prevented by existing connection restrictions, thermal distortion may produce deformation, or cause the onset of tension stresses which overcome the resistance of the concrete and may heighten the level of cracking and encourage the ingress of aggressive substances. Deterioration of the structures during use may also be amplified by freeze/thaw cycles at around 0 °C due to the increased pressure of the water present in the widespread saturated pores in the concrete, which is capable of causing stress destroying both the cement-based matrix and the aggregates and over time produce surface debonding and cracking.



Mechanical deterioration

The causes of mechanical deterioration of concrete derive from phenomena that compromise the structural strength and ability of the material to bear loads. The main mechanical causes include the poor quality of construction materials used and possible errors during installation, along with phenomena such as abrasion, impact, erosion and cavitation.

The factors that influence resistance to abrasion include compressive strength, the properties of aggregates, finishing, the presence of patches and the surface conditions. Industrial flooring is particularly vulnerable to these phenomena, due to the constant transit of vehicles.

The term “wear” describes both the stress and deterioration of the surface subject to friction. Erosion can be considered a form of surface wear. The phenomena typical of abrasion include contact and friction between the surfaces of concrete structures, together with the damage caused by solid particles transported in watercourses, such as gravel, stones and sand.



Reference standard: (UNI EN 1504).

The Technical Building Regulations have unambiguously established that operations on existing constructions, in particular operations on reinforced concrete, must be carried out using materials that have been identified and qualified by the manufacturer as compliant with the EN 1504 series of standards.

The series of harmonised European standards EN 1504 is made up of ten parts, in which parts 2-7 define the performance requirements for the different types of products and systems foreseen for the maintenance, repair and protection of existing concrete structures. The remaining parts relate to definition of the terms (part 1) relating to the products and systems for repair of the structures, to quality control and conformity assessment procedures (part 8) including product marking, to the general principles at the root of interventions to protect and repair structures (part 9), to the methods for use and application of the products on site and quality control relating to the execution of repair works (part 10).

EN 1504-1	Definitions
EN 1504-2	Surface protection systems: impregnating agents (i), waterproofing agents (h) and protective coatings (c)
EN 1504-3	Structural and non-structural repair
EN 1504-4	Structural bonding
EN 1504-5	Concrete injection
EN 1504-6	Anchoring of steel reinforcement meshes
EN 1504-7	Reinforcement corrosion protection systems
EN 1504-8	Quality control and assessment of conformity
EN 1504-9	General principles for the use of products and systems
EN 1504-10	On site application of the products, systems and quality control on the maintenance work

Substrate preparation:

EN 1504 part 10

The standard provides the requirements in relation to the state of the substrate before and during application, storage of systems and products, structural stability during preparation, protection and repair, protection and repair methods, quality control on the works and maintenance of the structures.

Preparation of the substrate is an essential step for success of the intervention, and it relates to preparation of both the concrete and the reinforcement.

Both must comply with the conditions set by the standards in order to ensure proper application of the products and systems, guaranteeing a highly durable intervention.

→ **Concrete preparation**

- 1) Remove the concrete, taking care not to reduce the structural integrity to an extent that prevents the structure from carrying out its function;
- 2) Roughen the surface, in a manner sufficient for the products and systems to be applied, by sanding, hydro-demolition or mechanical demolition;
- 3) Restrict micro-cracking on the surface of the substrate, so as not to compromise adhesion;
- 4) Clean the substrate to ensure it is free from dust, loose material, surface contaminants and materials that might reduce adhesion.

→ **Preparation of the reinforcement**

- 1) Remove any rust, scaling, dust and other loose materials that might reduce adhesion;
- 2) Clean the entire circumference of the exposed reinforcement;
- 3) Protect any cleaned surfaces if the protective products and systems are not to be applied immediately;
- 4) The reinforcement must be cleaned without damaging it and without damaging the adjacent concrete;
- 5) If the exposed reinforcement is contaminated by chlorides or other materials that trigger rusting, the entire circumference must be cleaned with water jets at above 18 MPa.

Metric range.

Metric is a full range of high technology products and systems specifically formulated for reinforced concrete structures, designed to offer traditional and effective solutions for the needs of specialist firms working on large job sites.

This product line reflects the in-depth knowledge of Kerakoll's researchers in the field of reinforced concrete repair and strengthening, which is added to the experience gained in providing technical assistance to businesses and planners engaged in large work site projects such as residential and public complexes, hospitals, schools, road infrastructure, bridges, viaducts, canals and industrial buildings.



Thixotropic mortars

Metric R4 Tixo

Fibre-reinforced thixotropic mortar with compensated shrinkage for reinforced concrete structural repair.

- Thixotropic, class R4
- Thicknesses from 10 to 50 mm in a single coat
- For structural layered repairs of reinforced concrete
- Good adhesion capacity when cast on ceiling intrados



Metric R3 Tixo

Fibre-reinforced thixotropic mortar with compensated shrinkage for reinforced concrete and masonry structural repair.

- Thixotropic, class R3
- Thicknesses from 10 to 50 mm in a single coat
- For structural layered repairs of reinforced concrete
- For the preparation of reinforced fine grain concrete on masonry



Metric R2 Fix

High ductility, fibre-reinforced thixotropic mortar for concrete and masonry reconstruction.

- Thixotropic, class R2
- Thicknesses from 2 to 40 mm in a single coat
- For non-structural repairs of concrete
- For repair of brick, stone and concrete structures



Fluid and road mortars, binders

Metric R4 Flow

Fibre-reinforced pourable mortar with compensated shrinkage for reinforced concrete structural repair.

- Pourable, class R4
- Thicknesses from 10 to 100 mm in a single coat
- For structural layered repairs of reinforced concrete
- Extremely fluid



Metric Anchor

Expansive pourable mortar for structural grouting.

- Pourable, class R4
- Expansive
- Thicknesses from 10 to 100 mm in a single coat
- For precision anchoring
- Extremely fluid



Metric Track

Rapid-setting, fibre-reinforced semi-thixotropic mortar for road, industrial and urban maintenance work.

- Grey and black colour
- Semi-thixotropic, class R4
- Rapid setting 20 min
- Thicknesses from 10 to 100 mm
- Specific for road and street furniture works



Metric Binder

High-performance, expansive, superfluid cement-based binder for concrete, fine grain concrete and mortar.

- High fluidity and expansion
- EN 1504-6 certified
- For consolidating injections and precision grouting
- For the preparation of concrete and fine grain concrete



Protective and waterproofing products

Metric Rebar

Anti-corrosive cement-based protective product for reinforcing bars.

- Thixotropic
- EN 1504-7 certified, single layer
- Active reinforcement protection
- Passive reinforcement protection, thanks to corrosion inhibitors



Metric Protection

Anti-carbonation, elastic, cement-based protective product for concrete.

- Thixotropic
- certified EN 1504-2 (C)
- For the protection of cracked elements
- Resistant to environmental aggressions
- Water-resistant



Metric Osmotic

Waterproofing, osmotic, cement-based protective product for concrete.

- White and grey
- Thixotropic
- Certified EN 1504-2 (C)
- Certified as suitable for the containment of drinking water
- Excellent levels of resistance to abrasion



Metric Ultracem

Extra-quick-setting and hardening mortar for instant blocking of water leaks.

- Immediate blockage of water leaking in negative pressure
- Developing high levels of mechanical resistance in a very short time
- For permanent contact with water under pressure



Metric Epocoat

Epoxy protective product with high chemical resistance for concrete.

- Certified EN 1504-2 (C)
- For the protection against severe attacks
- Colour grey
- High coverage



Epoxy systems, primers and complementary products

Epobinder

Fluid epoxy system for construction joints, grouting on concrete, synthetic mortars and finishings.

- Excellent workability
- For the execution of construction joints
- To make epoxy finishings and screeds
- Ideal to seal cracks in mineral or cement-based screeds



Epofill

Hyperfluid epoxy system for the injection of cracks and grouting on concrete.

- Low viscosity
- Rapid hardening
- For the injection of cracks on concrete
- For precision anchoring



Primer Uni

Universal, consolidating adhesion promoter for mortars and plasters/renders.

- Extremely fluid, high stabilizing and impregnating power
- Suitable for absorbent and non-absorbent substrates
- Rapid drying



Ghiaia 3.6

Gravel with 3-6 mm grading curve.

- Optimises the grading curve of the mortar according to the thickness of application
- Excellent mixing properties
- Excellent adhesion to hydraulic binders



Application framework

	Thixotropic mortars			Fluid and road mortars, binders				Protective and waterproofing products				Epoxy systems, primers and complementary products				
	Metric R4 Tixo	Metric R3 Tixo	Metric R2 Fix	Metric R4 Flow	Metric Anchor	Metric Track	Metric Binder	Metric Rebar	Metric Protection	Metric Osmotic	Metric Ultracem	Metric Epocoat	Epobinder	Epofill	Primer Uni	Ghiaia 3.6
Vertical structures																
Structural repair	●	●						●	●							
Jacketing of pillars				●												●
Reinforced fine grain concrete		●														
Restoration of basements with water under negative thrust		●								●						
Cortical repair			●													
Filling of cracks														●		
New construction of reinforced concrete element							●		●							
Protection of concrete									●							
Protection from chemical aggression			●									●				
Repair and waterproofing of reservoirs for the containment of drinking water	●	●						●		●						
Repair and waterproofing/protection of tanks containing aggressive chemicals	●	●						●		●		●				
Immediate blocking of water leakage											●					
Horizontal structures																
Anchoring and fastening of metal elements					●								●	●		
Repair of manholes and street furniture						●										
Construction joints													●			
Sloped flooring						●										
Structural repair of flat industrial flooring				●											●	
Cortical repair of industrial floorings													●			
Road expansion joints						●										●

Areas of intervention.

The traditional range of products and systems for the reconstruction, repair and protection of concrete structures can be used in various areas of intervention.

More specifically, the three main types of intervention include:

→ **Non-residential buildings**

Traditional mortars can be used to repair, rebuild and protect damaged parts of non-residential and commercial buildings, such as walls, pillars, floors and foundations.

→ **Industrial environments**

Industrial structures that are exposed to severe environmental conditions may benefit from traditional systems for the repair and protection from aggressive agents and structural deterioration.

→ **Infrastructures**

Concrete structures in road infrastructures, such as bridges and viaducts, may benefit from the application of mortars that are specifically designed to deal with damage caused by atmospheric agents, heavy loads and wear.

The Metric range plays a leading role when used in repair and reinforcement operations, helping to maintain stability and prevent deterioration, offering versatile solutions for a variety of contexts.



Non-residential



→ Restoration of basements with water under negative thrust

→ Cortical repair

→ Repair of manholes and street furniture

→ Protection of
concrete

→ Anchoring and fastening
of metal elements

→ Restoration

Non-residential

→ Sealing of cracks

→ Jacketing of pillars

→ Cortical repair of industrial floorings



→ Structural repair

→ Protection of concrete

Industrial and tanks

→ Reinforced fine
grain concrete

→ Cortical repair of
industrial floorings

→ Anchoring and
fastening of metal
elements

→ Repair of manholes and
street furniture



→ Sealing of cracks

→ Structural repair

← Protection of structures from chemical aggression

Industrial and tanks

→ Anchoring and
fastening of metal
elements

→ Restoration of
basements with
water under
negative thrust

→ Protection of
structures from
chemical aggression



Repair and ←
waterproofing/
protection of tanks
containing aggressive
chemicals

→ Repair and waterproofing
of reservoirs for the
containment of drinking
water

→ Immediate
blocking of water
leakage

Infrastructural



→ Anchoring and fastening
of metal elements

→ Jacketing of pillars
or other structural
elements



→ **Protection from
chemical aggression**

→ **Protection of
concrete**

→ **New construction of
reinforced concrete
element**

Infrastructural



→ **Structural repair**

→ **Cortical repair of
road pavings**

→ **Road expansion
joint**



Protection of ←
concrete

Repair and reconstruction

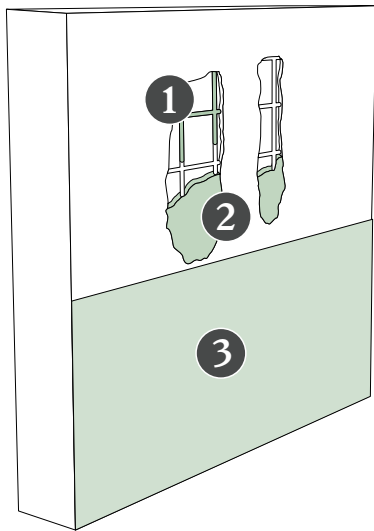

Structural repair

- 1 Metric Rebar
- 2 Metric R4 Tixo
- 3 Metric Protection

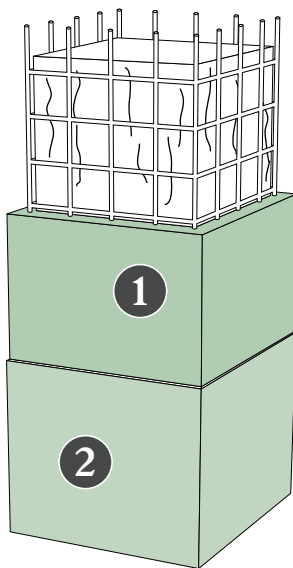

Jacketing of pillars or other structural elements

- 1 Metric R4 Flow + Ghiaia 3.6
- 2 Metric Protection

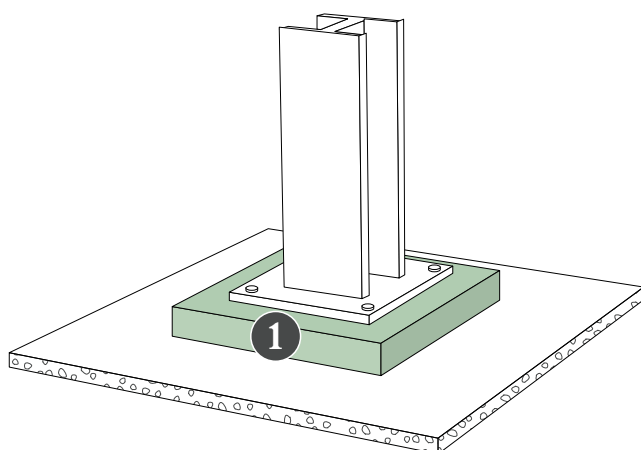

Anchoring and fastening of metal elements

- 1 Metric Anchor

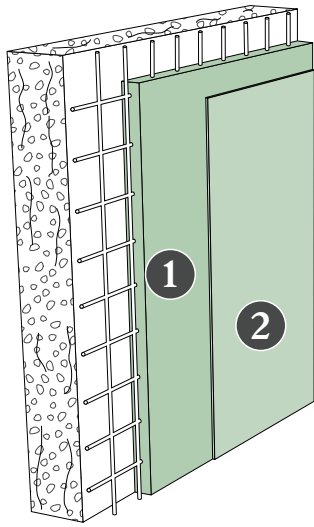

Reinforced fine grain concrete

-
- 1 Metric R3 Tixo + electro-welded mesh
-
- 2 Metric Protection
-

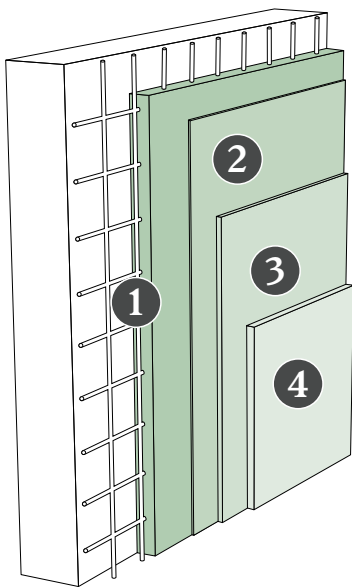

Restoration of basements with water under negative thrust

-
- 1 Metric R3 Tixo + electro-welded mesh
-
- 2 Metric Osmotic
-
- 3 Biocalce Rinzafo
-
- 4 Biocalce Zoccolatura
-

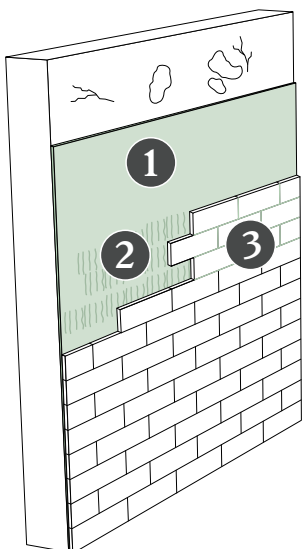

Cortical repair

-
- 1 Metric R2 Fix
-
- 2 Tetra Tack
-
- 3 Tetra Seal
-

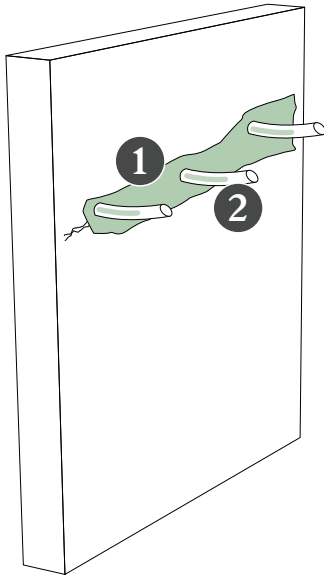

Sealing of cracks

- 1 Geolite Gel
- 2 Epofill

Repair of manholes and street furniture

- 1 Metric Track

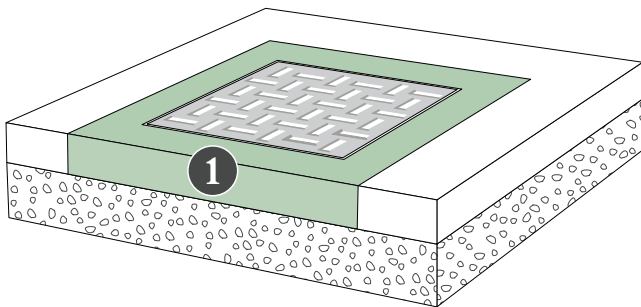

New construction of reinforced concrete element

- 1 Metric Binder + sand, fine concrete aggregate and gravel
- 2 Commercial inert material + electro-welded mesh
- 3 Metric Protection

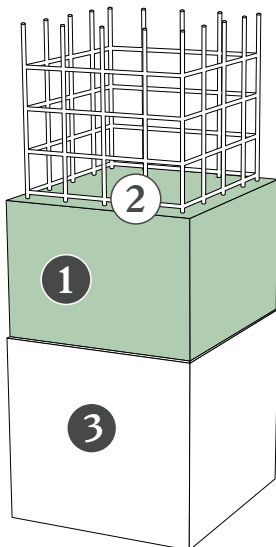

Protection and waterproofing

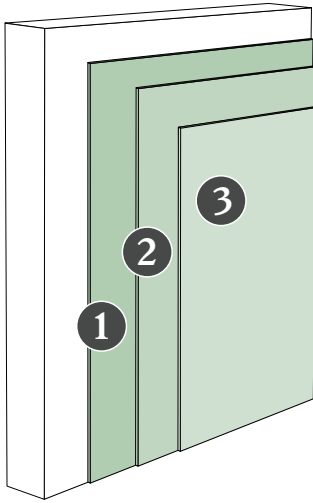

Protection of concrete

-
- 1 Metric Protection
-
- 2 Kerakover Acrilex Fondo
-
- 3 Kerakover Acrilex Flex
-

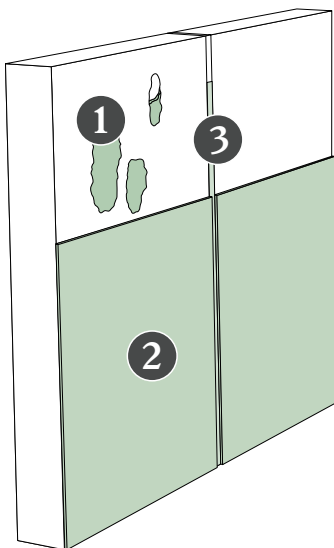

Protection from chemical aggression

-
- 1 Metric R2 Fix
-
- 2 Metric Epocoat
-
- 3 Tetra Seal
-

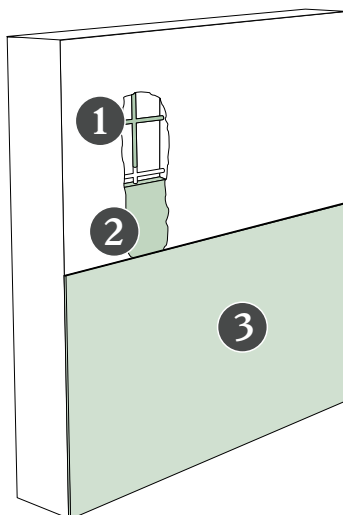

Repair and waterproofing of reservoirs for the containment of drinking water

-
- 1 Metric Rebar
-
- 2 Metric R3 Tixo
-
- 3 Metric Osmotic
-

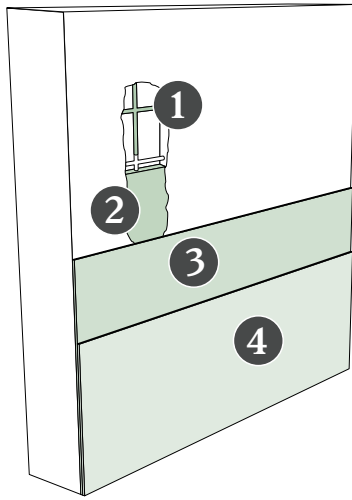

**Repair and waterproofing/
protection of tanks containing
aggressive chemicals**

-
- 1 Metric Rebar
-
- 2 Metric R4 Tixo
-
- 3 Metric Osmotic
-
- 4 Metric Epocoat
-

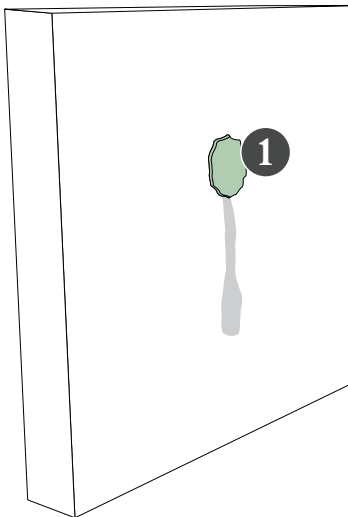

**Immediate blocking of water
leakage**

-
- 1 Metric Ultracem
-

Flooring

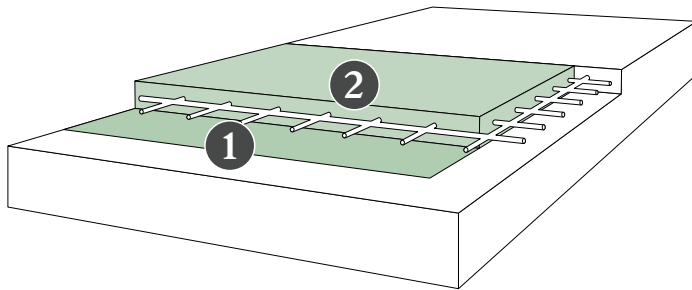

Construction joints

- 1 Epobinder
- 2 Metric R4 Flow

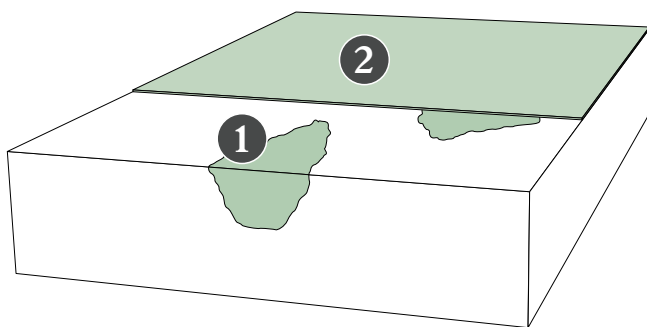

Sloped flooring

- 1 Metric Track
- 2 Thin multi-layer system, Factory range

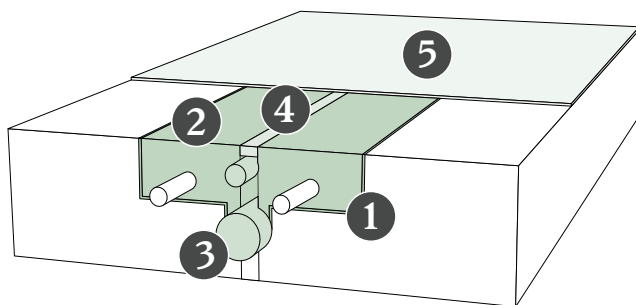

Structural repair of flat industrial flooring

- 1 Primer Uni
- 2 Metric R4 Flow
- 3 Joint
- 4 Tetra Seal
- 5 Thin multi-layer system, Factory range

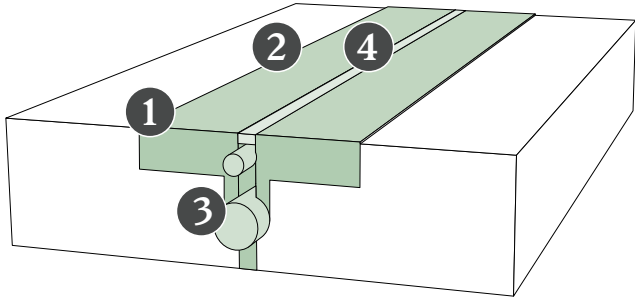

Cortical repair of industrial floorings

- | | |
|---|-------------------------|
| 1 | Epobinder + Quarzo 1.7 |
| 2 | Dusting with Quarzo 1.7 |
| 3 | Joint |
| 4 | Tetra Seal |

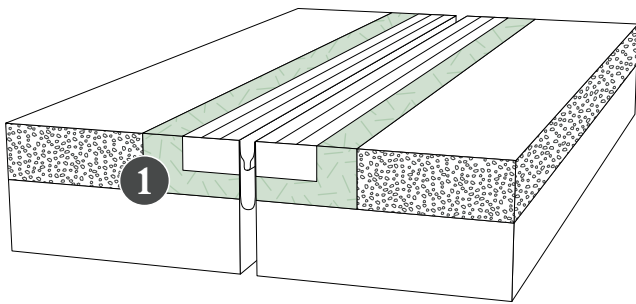

Road expansion joints

- | | |
|---|----------------------------|
| 1 | Metric Track + Steel Fiber |
|---|----------------------------|

kerakoll



kerakoll.com